

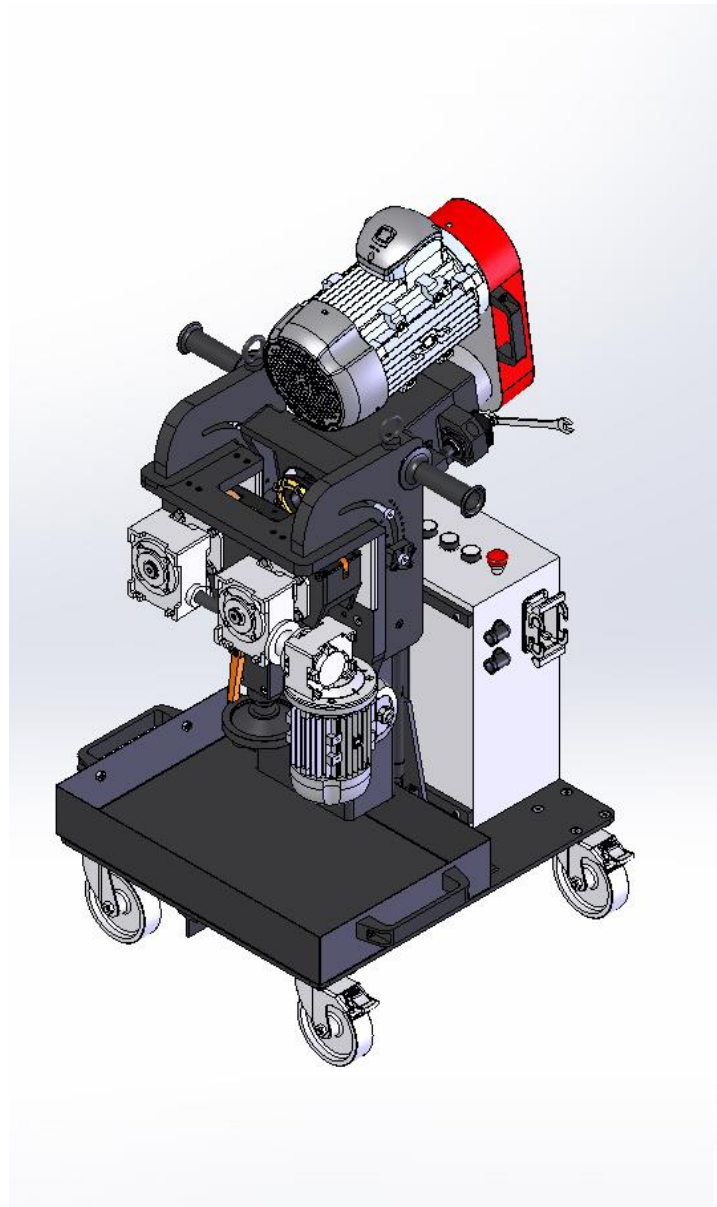

# INSTRUCTION MANUAL



## EDGE 80

Range w.t. 6-120mm (5/21"- 4 3/4")

**G.B.C. Industrial Tools S.p.A.**

Via Sandro Pertini 41/43 - 25046 Cazzago San Martino (Bs) - Italia - Tel. + 39 030 7451154 - Fax. + 39 030 73 56 629



# EDGE 80

Original Instructions —rev.2013—in compliance with § 1.7.4 of the Machine Directive 2006/42/CE

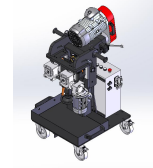

## Index

Presentation of the Company and introduction to the Instruction Manual	3
Warranty General Causes	4
Intended use of the EDGE 80	5
Technical Features	6
Machine Standard Equipment	7
Safety Prescriptions	8
Machine Stability	10
Workplace	10
Emergency Stop	10
Setup	11
Setup for “J” Bevel	18
Controls	22
Inserts Replacement	25
Warnings and Troubleshooting	28
Installation and use of the Face Mill Speed Regulator	29
Ordinary Maintenance	34

## G.B.C. Industrial Tools S.p.A.

Via Sandro Pertini 41/43 – 25046 Cazzago San Martino (Bs) – Italia – Tel. + 39 030 7451154 – Fax. + 39 030 73 56 629



# EDGE 80

Original Instructions —rev.2013—in compliance with § 1.7.4 of the Machine Directive 2006/42/CE

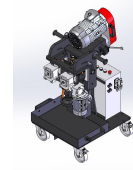

## **PRESENTATION OF THE COMPANY AND INTRODUCTION TO THE INSTRUCTION MANUAL**

**G.B.C. Industrial Tools S.p.A.** is known worldwide for the quality of its machines and accessories **for pipe cutting and beveling procedures** of any sort and **plate beveling machines**.

The Headquarters are located in Cazzago San Martino (BS) where are currently operating the General Management, the sales de-department, as well as the main workshop and the shipping department.

**QUALITY STANDARD**—All our machines are assembled according to the highest quality standard. Since 1996 G.B.C. Industrial Tool S.p.a. has implemented management procedures in compliance with the quality system regulations UNI EN ISO 9001 (SGS ITALIA S.R.L. N° IT 96.088 / 1996).

This **Manual** is supplied together with the machine it makes reference to. The customer may apply for further copies to **G.B.C. Industrial Tools S.p.A.** Our company owns the copyright of this document and any partial or complete copy or distribution to natural persons or to corporate bodies is strictly forbid-den unless our prior approval to do so is obtained. **G.B.C. Industrial Tools S.p.A.**

informs its customers that any operation carried out on the machines which is not prescribed in this manual entails the automatic invalidation of the warranty. **G.B.C. Industrial Tools S.p.A.**

recommends to contact the Maintenance Service in Torbiato di Adro – Italy prior to proceed with any modification on the machine.

**You are invited to scrupulously adhere to the information written on the identification tag.**

For any further information you are invited to contact us at these numbers:

**Tel. +39 - 030 - 7451154**  
**Email : sales@gbcspa.com**

**G**

**G.B.C. Industrial Tools S.p.A.**

Via Sandro Pertini 41/43 – 25046 Cazzago San Martino (Bs) – Italia – Tel. + 39 030 7451154 – Fax. + 39 030 73 56 629



# EDGE 80

Original Instructions —rev.2013—in compliance with § 1.7.4 of the Machine Directive 2006/42/CE

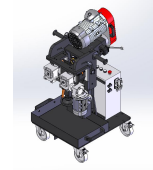

## **WARRANTY GENERAL CLAUSES**

**G.B.C.** guarantees the reliability of the machine and its conformity to the specifications herewith reported. The warranty covers the machine in its whole for a time period of one year from the shipment date (ref. Delivery Note) for any flaw not imputable to the user. The parts subject to wear are excluded from the warranty at sole discretion of **G.B.C.**.

In case of any operational malfunction arising during the warranty period, **G.B.C.** And its Maintenance Service, hereinafter called **MSS**, will remedy this inconvenient free of charge, both for handwork and for eventual replaced parts, except when the malfunction is directly or indirectly imputable to misuse or alteration. In any case the machine must not be disassembled or altered before the shipment. The warranty is valid only when the warranty document is duly signed by **G.B.C.** and by a **G.B.C.** official distributor connected with the **MSS** maintenance service.

The shipment of the defective material must be performed within 8 (eight) days from the notification of the defect and/or the claim and/or the request of technical assistance. On the contrary the warranty will be void. **G.B.C.** and **MSS** obligations will cover the defect resolution, the general maintenance and the inspection of the parts subject of the claim only. The component replacement is at **G.B.C.** discretion only. The shipment to costs from and to the **MSS** as well as the direct and indirect costs rising from repair of the product are at user's charge. Any warranty repair or extraordinary repair must be executed by **G.B.C.** and **MSS**, otherwise the warranty will be void.

Any ordinary maintenance performed by the customer/user or by any service centre non recognized or approved by **G.B.C.** will not be refunded and will make the warranty void. The warranty is not valid for cases not listed in this certificate or for damage caused by a misuse of materials, power supply, negligence, unauthorized modifications, atmospheric events, acts of vandalism, incautious handling and/or transport, use of non original **G.B.C.** parts and damage for causes not specified by **G.B.C.** and for which **G.B.C.** declines any responsibility. **G.B.C.** reserves the right to modify and to improve its products without any obligation to modify equipment and components already supplied. Nobody is authorized to modify the conditions herewith contained or to issue any on behalf of **G.B.C.** The claim terms for defects and/or damages in the material or of the ordered quantities, are those pre-scribed by the Civil Code; the goods acceptance entails the buyer to automatically accept the above mentioned warranty clauses.

## **G.B.C. Industrial Tools S.p.A.**

Via Sandro Pertini 41/43 – 25046 Cazzago San Martino (Bs) – Italia – Tel. + 39 030 7451154 – Fax. + 39 030 73 56 629



# EDGE 80

Original Instructions —rev.2013—in compliance with § 1.7.4 of the Machine Directive 2006/42/CE

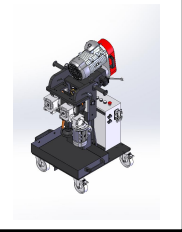

## **INTENDED USE OF THE EDGE80**

GBC's plate bevellers, can perform a welding prep bevel on 90° edges. There are several models available depending by the wall thickness of the plate, usable for on-site jobs and for workshop daily production purposes.

All machines are equipped with an automatic feeding system, therefore once they are positioned and locked on the plate edge (models for beveling the upside and models for beveling the down side of the plate), the beveling is performed automatically, with no need of any intervention by any operator. These machines are equipped with a comfortable trolley designed ad-hoc, adjustable in height and particularly useful when working large plate sheets so that no overhead cranes or other lifting devices has to be involved in the process. GBC's plate bevellers can be divided in two typologies::

### GBC CHALLENGE (12/15)

Locking Range 6-40mm wall thickness . Adjustable beveling angle from 22° to 55°, completely silent, milling head with toothed edge, high speed beveling without operator intervention.

### GBC EDGE 80 range w.t. 6-120mm

Adjustable Bevel angle from 10° to 70°, high speed RPM face mill with inserts, high finishing grade and increased material removal capacity per pass.

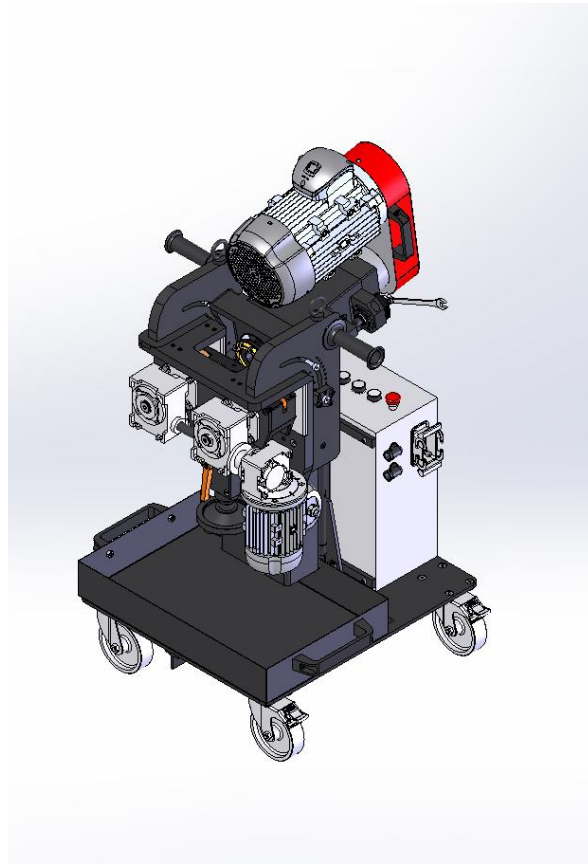

THE MACHINE SHOULD BE OPERATED ONLY BY SPECIALIZED OPERATORS WHO HAVE BEEN DULY TRAINED ON THE UNIT.

FOLLOWING TO A SPECIFIC FORMATION WE DO NOT ENVISAGE ANY REASONABLY

## **G.B.C. Industrial Tools S.p.A.**

Via Sandro Pertini 41/43 – 25046 Cazzago San Martino (Bs) – Italia – Tel. + 39 030 7451154 – Fax. + 39 030 73 56 629

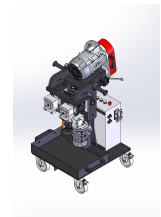

## **TECHNICAL DATA**

		<b>ELECTRIC</b>
<b>Electric Motor Power</b>	W	4000
<b>Tension</b>	Volt	230 / 400
<b>Frequency</b>	Hz	50 / 60
<b>Face Mill Speed</b>	rpm	300 ÷ 1500
<b>Face Mill Type</b>		Ø80mm - 9 inserts
<b>Bevel Angle</b>		Da 10° a 70°
<b>“J” Bevel Angle</b>		Da 0° a 30°
<b>Plate Thickness</b>	mm	Min. 6 - Max 120
<b>Bevel Diagonal Length</b>	mm	Min. 0 - Max 80
<b>Travel Speed</b>	Mt/min	0 ÷ 1.5
<b>Weight</b>	Kg	221
<b>Acoustic Emissions</b>	dB	76

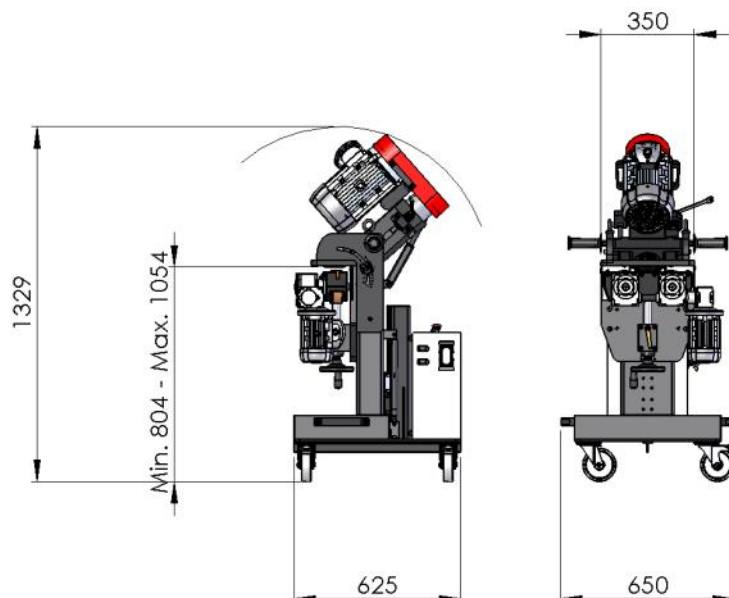

**G.B.C. Industrial Tools S.p.A.**

Via Sandro Pertini 41/43 – 25046 Cazzago San Martino (Bs) – Italia – Tel. + 39 030 7451154 – Fax. + 39 030 73 56 629

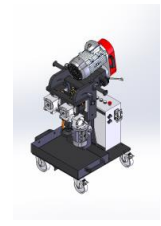

## **MACHINE STANDARD EQUIPMENT**

The machine is supplied with:

- Service Tools
- Face Mill with 9 inserts already installed
- Storage Wooden Box
- Instruction Manual
- Drawings

### **EDGE80**

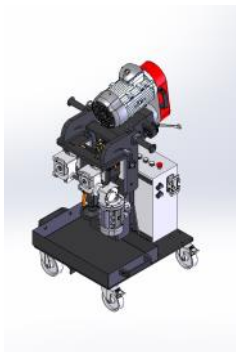

### **Service Tools**

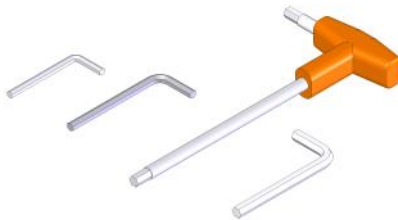

### **Face Mill**



### **Storage Box**



### **Instruction Manual and Drawings**



**G.B.C. Industrial Tools S.p.A.**

Via Sandro Pertini 41/43 – 25046 Cazzago San Martino (Bs) – Italia – Tel. + 39 030 7451154 – Fax. + 39 030 73 56 629

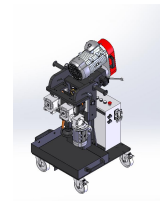

## **SAFETY PRESCRIPTIONS**

G.B.C. Industrial Tools S.p.A. designs and assembles its machines in strict compliance with the safety regulations provided by the applicable EC directives and by the Italian laws regulating this matter.

G.B.C. Industrial Tools S.p.A. declines any responsibility for misuse of its machines and their use when in contrast with the regulation listed hereinafter and with the use and maintenance instructions hereto.

- Carefully read ALL the following regulations and the instructions herewith attached before starting any operation.
- Carefully ensure that the operator and the foreman using the machine are fully aware of all the regulations and all the instructions and that they are qualified to operate the unit.
- Strictly attain to the indications given by the international symbols applies on the machine and/or on its case.
- Do not perform any maintenance operation when the machine is plugged to the power supply.
- Before every use, ensure the power supply connections to be conform to the specs given by our manual.  
alle caratteristiche specificate nel manuale G.B.C.

The authorized operator in any case will not have to disregard the basic safety rules such as:

- Using gloves and goggles (safety gear supplied by the company responsible for the site or for the building)
- To properly illuminate the working area
- Ensure you are operating in an area which grants free movements (at least 1,5 metres around the operator)
- Do not replace the control system and do not replace parts with non original spare parts, and do not project violent water squirts on the machine
- Keep the hands away from hot and sharpened parts.
- 
- G.B.C. Industrial Tools S.p.A. remarks that for any non specified circumstances it is necessary to obtain the authorization of the manufacturer.

**G.B.C. Industrial Tools S.p.A.**

Via Sandro Pertini 41/43 – 25046 Cazzago San Martino (Bs) – Italia – Tel. + 39 030 7451154 – Fax. + 39 030 73 56 629



# EDGE 80

Original Instructions —rev.2013—in compliance with § 1.7.4 of the Machine Directive 2006/42/CE

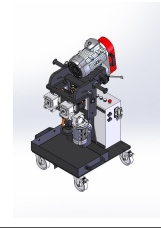

Using properly the safety gear entails the only risks to be generated by the user’s system and not by inborn defects of our machines.

The acoustic emissions are within the limits provided by Machine Directive in force. Proof of this is recorder and stored by the production department which files all the acoustic tests performer on every single unit.

1. Always wear gloves and goggles during every operation
2. Any adjustment or inspection of the machine shall be done with the unit unplugged from the power source.
3. During the operations the hands of the operator must be kept on the handles located on the sides of the motor.
4. The Use and Maintenance Manual as well as the drawings will always supply quick and adequate explanations.



## SHIPPING DETAILS

Shipment Weight	kg	<b>221</b>	
Shipping Dimensions	mm	122 x 98x 158	
Shipping Weight	kg	<b>321</b>	

## G.B.C. Industrial Tools S.p.A.

Via Sandro Pertini 41/43 – 25046 Cazzago San Martino (Bs) – Italia – Tel. + 39 030 7451154 – Fax. + 39 030 73 56 629



# EDGE 80

Original Instructions —rev.2013—in compliance with § 1.7.4 of the Machine Directive 2006/42/CE

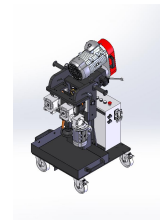

## **MACHINE STABILITY**

Considering the mass of the machine no particular problem has been detected in regard to the operator safety.

## **EMERGENCY STOP INSTALLATION**

The machine is equipped with an emergency stop button — See the paragraph regarding the controls.

**G.B.C. Industrial Tools S.p.A.**

Via Sandro Pertini 41/43 – 25046 Cazzago San Martino (Bs) – Italia – Tel. + 39 030 7451154 – Fax. + 39 030 73 56 629

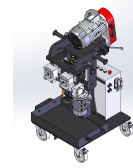

## **EDGE80 SETUP**

Before starting any setup operation, make sure the machine is clean and that it is not connected to the main power supply. In particular ensure to clean those areas where you will have to act to make the required adjustments.

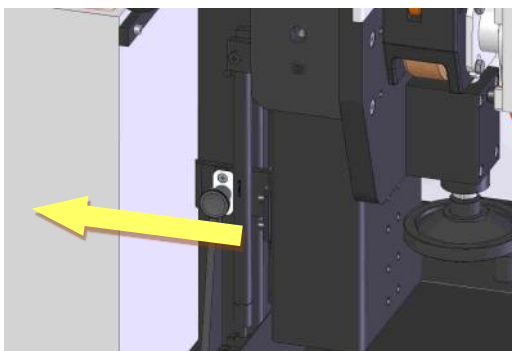

Remove the two Transport Locking Screws to release the machine head from the base

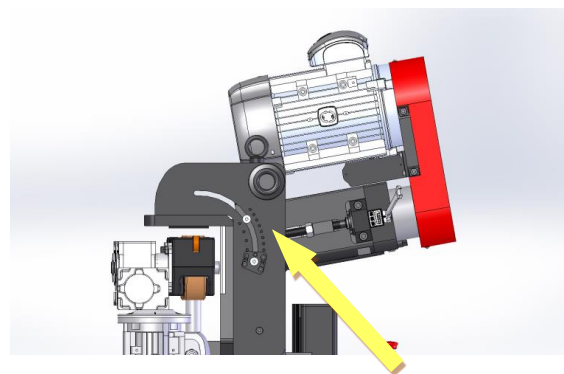

Remember to loosen the locking screws before adjusting the bevel angle.

**N.B. : Keep clean and lubricated the moving parts of the head.**

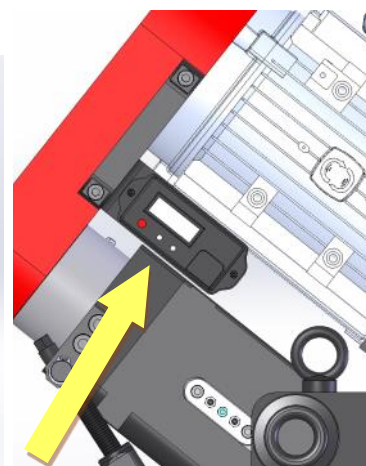
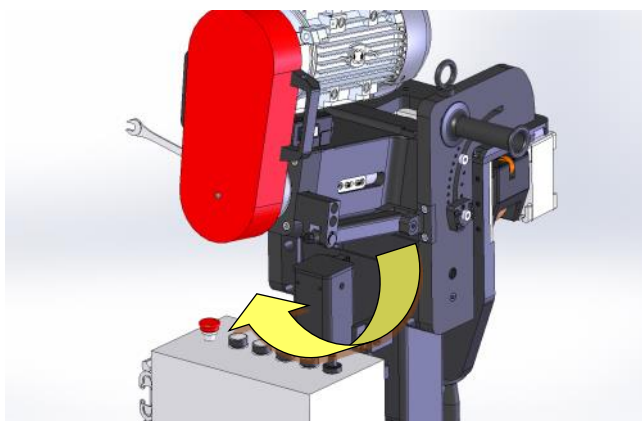

The angle can be adjusted by acting on the hand wheel and checking the angle gauge.

**G.B.C. Industrial Tools S.p.A.**

Via Sandro Pertini 41/43 – 25046 Cazzago San Martino (Bs) – Italia – Tel. + 39 030 7451154 – Fax. + 39 030 73 56 629

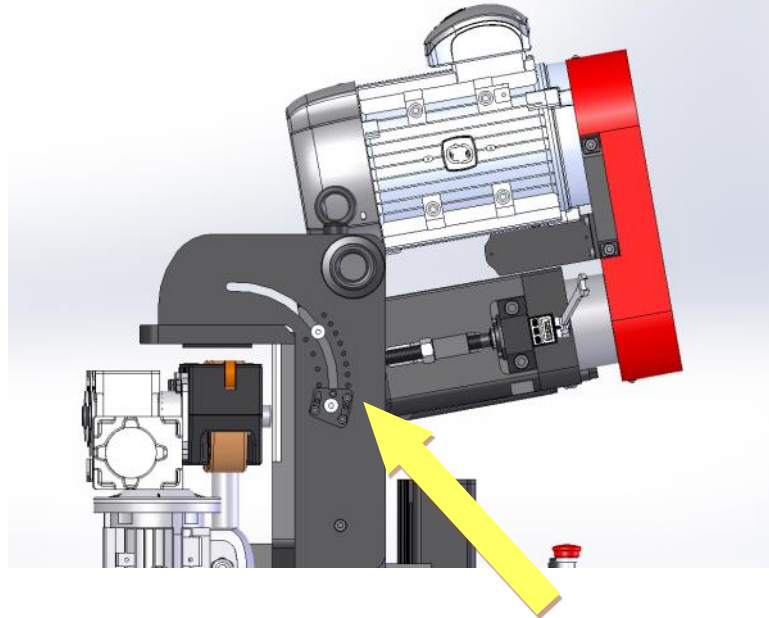
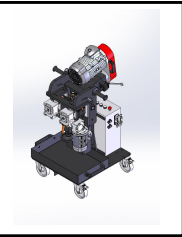

Once the bevel angle is set, tighten the locking screws to secure the central body in the selected position.

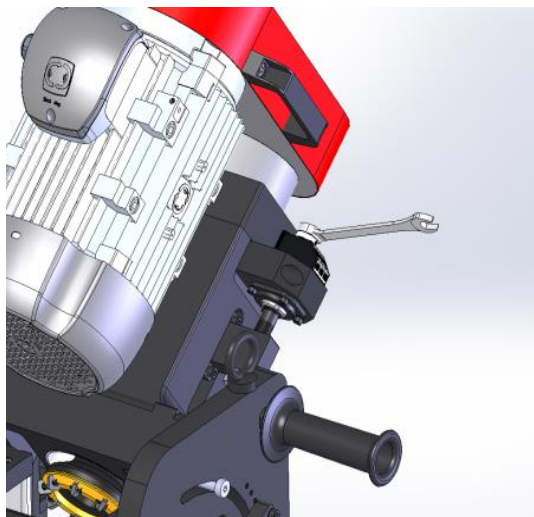

To increase the pass depth, thus the length of bevel, in first place you will need to loosen the locking nut of the DEPTH ADJUSTMENT ASSEMBLY.

**G.B.C. Industrial Tools S.p.A.**

Via Sandro Pertini 41/43 – 25046 Cazzago San Martino (Bs) – Italia – Tel. + 39 030 7451154 – Fax. + 39 030 73 56 629

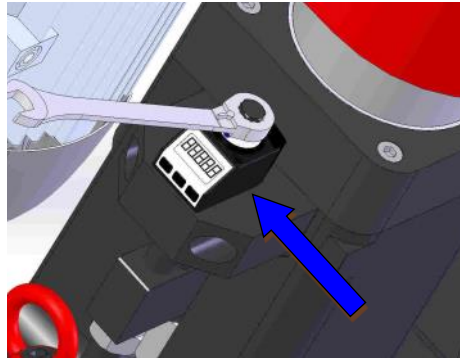
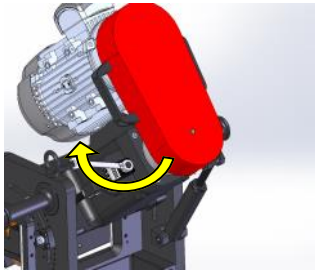
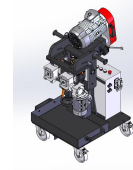

Now you can turn the hexagonal head of the feeding screw with the ratchet wrench supplied with the unit checking the actual depth on the LCD display just beneath it. In the below charts you can see some examples of beveling passes.

15° Angle				
Pass	Pass Depth	A	B	L
1	6	23.18	6.21	24
2	4.11	39.06	10.46	40.44
3	3.14	51.17	13.71	52.98
4	2.62	61.28	16.42	63.45
5	2.29	70.13	18.79	72.61
6	0.15	70.70	18.94	73.19

45° Angle				
Pass	Pass Depth	A	B	L
1	6	8.49	8.49	12
2	6	16.97	16.97	24
3	4.91	23.91	23.91	33.82
4	3.98	29.54	29.54	41.78
5	3.42	34.37	34.37	48.61
6	3.04	38.67	38.67	54.69
7	2.76	42.57	42.57	60.21
8	2.54	46.17	46.17	65.30
9	2.37	49.52	49.52	70.04
10	2.23	52.68	52.68	74.50
11	2.11	55.66	55.66	78.72
12	0.65	56.57	56.57	80

For specific settings of the Face Mill RPM, travel speed, type of materials and different angles you are invited to contact the sales department for an in-depth analysis of your application.

- Max Speed during the plate entering phase 0.2m/min
- Max Speed during the plate exiting phase 0.2m/min
- The beveling speed with a fully engaged plate is variable depending by the bevel angle, depth of the pass and by the material of the plate.

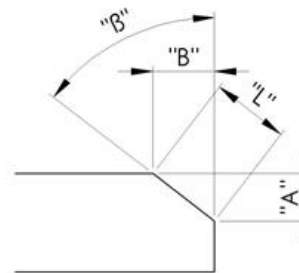

**G.B.C. Industrial Tools S.p.A.**

Via Sandro Pertini 41/43 – 25046 Cazzago San Martino (Bs) – Italia – Tel. + 39 030 7451154 – Fax. + 39 030 73 56 629

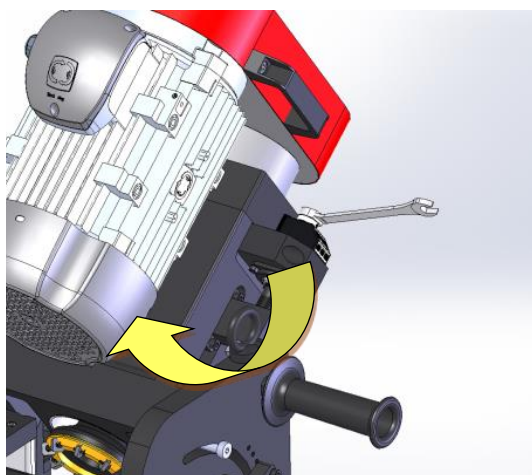
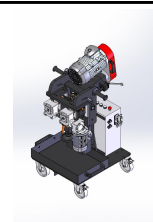

Once the pass depth is set, tighten the locking nut.

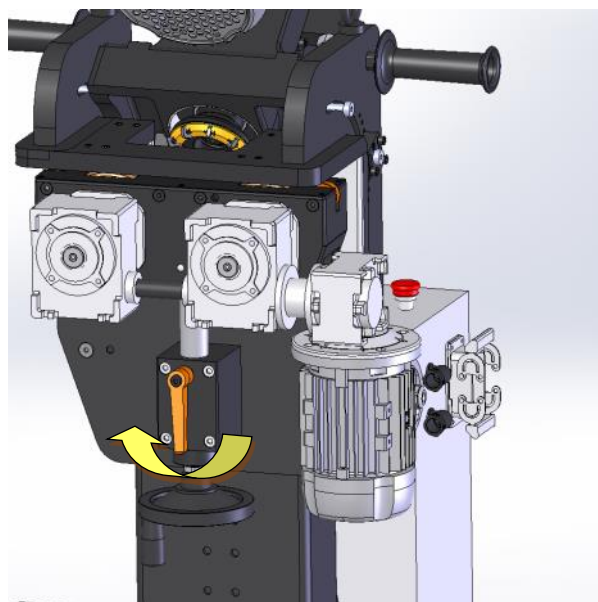

Loosen the SECURITY LEVER of the PLATE LOCKING ASSEMBLY.

**G.B.C. Industrial Tools S.p.A.**

Via Sandro Pertini 41/43 – 25046 Cazzago San Martino (Bs) – Italia – Tel. + 39 030 7451154 – Fax. + 39 030 73 56 629

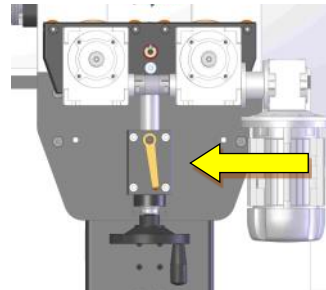
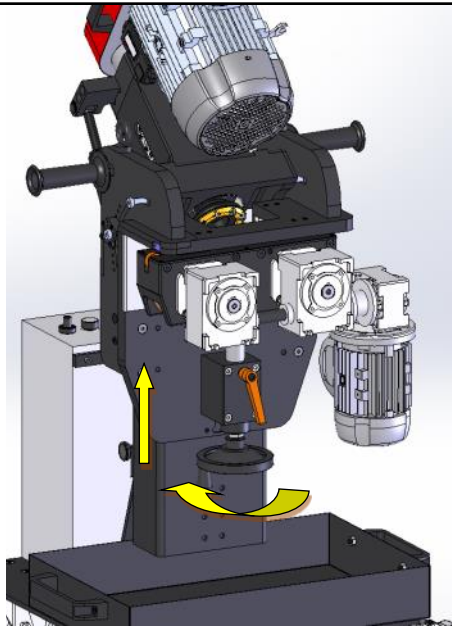
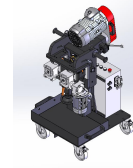

Position of the PLATE LOCKING ASSEMBLY for plate thickness 6 mm - 85 mm

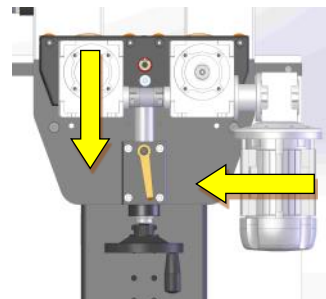

Position of the PLATE LOCKING ASSEMBLY for plate thickness 65mm a 120mm

The PLATE LOCKING ASSEMBLY can be opened and closed to match the plate thickness by acting on the hand wheel.

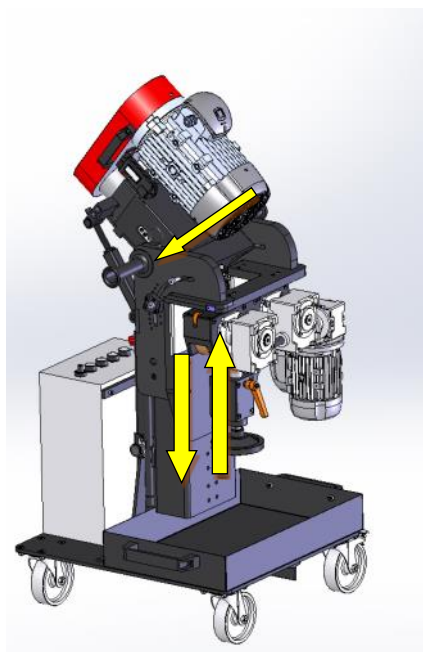

The upper part of the machine can be raised or lowered just by pulling up or pushing down on the handles.

**G.B.C. Industrial Tools S.p.A.**

Via Sandro Pertini 41/43 – 25046 Cazzago San Martino (Bs) – Italia – Tel. + 39 030 7451154 – Fax. + 39 030 73 56 629

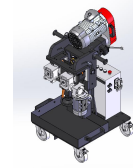

**Y  
E  
S**



While approaching the plate, make sure the wheels of the trolley are all facing the direction of motion so that they will not interfere with the linear travel of the unit.

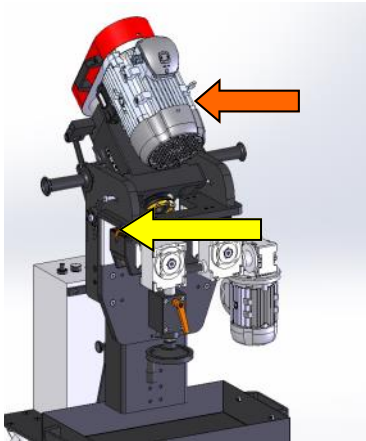

Move and position the machine on the plate using the handles making sure you are approaching the plate with the side where the plate detecting sensor is located.

**N  
O**



Act on the hand wheel to raise the PLATE LOCKING ASSEMBLY until it touches the plate and you feel some resistance on the hand wheel. Make another half turn of the hand wheel and tighten the orange LOCKING LEVER to secure the position of the PLATE LOCKING ASSEMBLY.

Adjust the height of the unit so that the plate is positioned right between the rubber wheel (blue arrow) and the flat roller (yellow arrow).

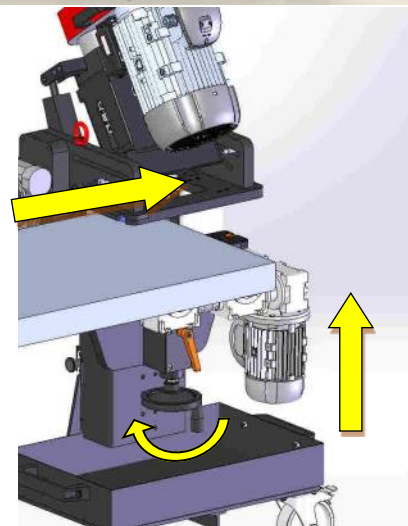
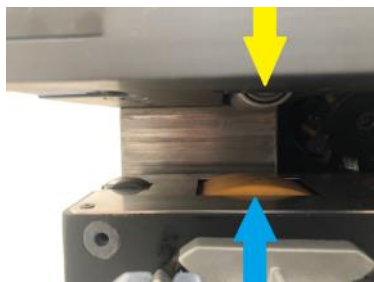

**The plate to be beveled should be clean from grease and oil in order to grant the machine an optimal grip. Any welding cap or imperfections caused by the oxycut will have to be grinded off for because they may interfere with the machine travel.**

**G.B.C. Industrial Tools S.p.A.**

Via Sandro Pertini 41/43 – 25046 Cazzago San Martino (Bs) – Italia – Tel. + 39 030 7451154 – Fax. + 39 030 73 56 629

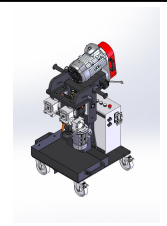

**When the plate is locked in position make sure it is parallel to the ground.**

***N.B.***

**When the plate is locked ensure that it is correctly engaging the PLATE DETECTION SENSOR otherwise the machine will not start.**

**Always insert the plate from the side of the sensor because the machine moves from left to right (view of the operator being behind the machine).**

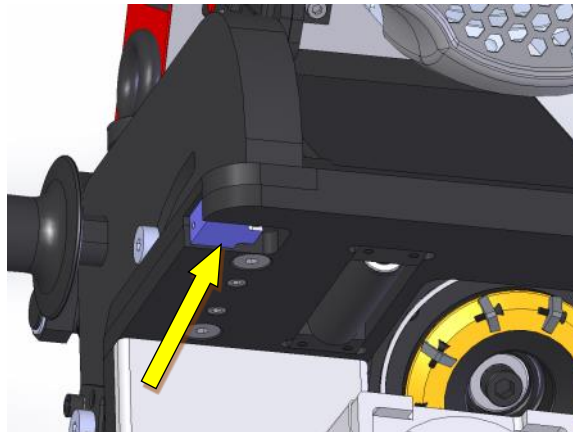

**G.B.C. Industrial Tools S.p.A.**

Via Sandro Pertini 41/43 – 25046 Cazzago San Martino (Bs) – Italia – Tel. + 39 030 7451154 – Fax. + 39 030 73 56 629

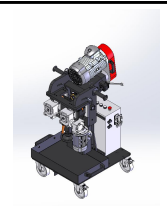

## **SETUP FOR "J" BEVEL**



WARNING. Before any setting takes place ensure the machine is duly cleaned especially in those areas interested by the setting and that it is unplugged from the electric power source.

WARNING. Before proceeding with the setting install the face mill with round inserts following the procedure described in the following paragraphs.

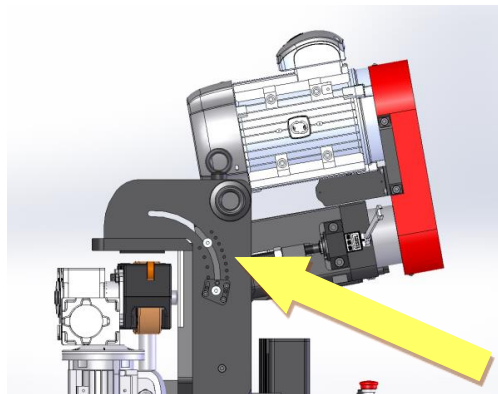

The bevel angle adjustment can be achieved by loosening the set screws (4 in total) located on the sides of the machine frame.

**N.B. : This area must be kept adequately clean and lubricated.**

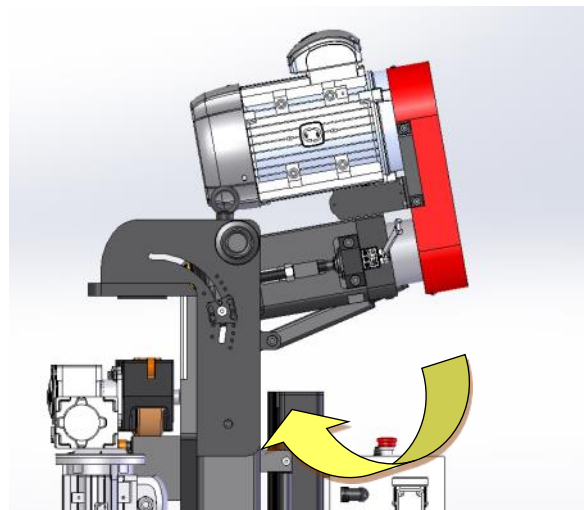
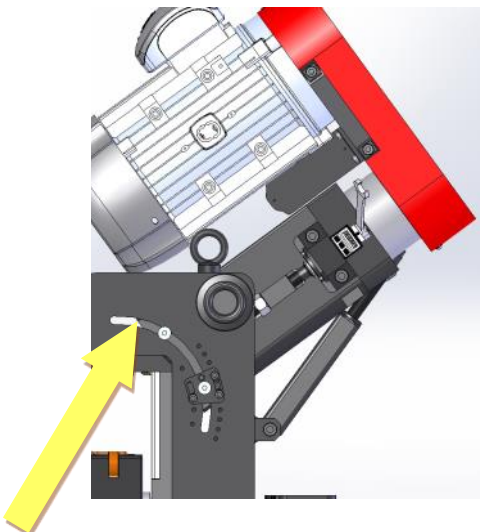

Remove the 2 upper set screws and by using the hand wheel move the head of the machine until it reaches the desired angle.

**G.B.C. Industrial Tools S.p.A.**

Via Sandro Pertini 41/43 – 25046 Cazzago San Martino (Bs) – Italia – Tel. + 39 030 7451154 – Fax. + 39 030 73 56 629

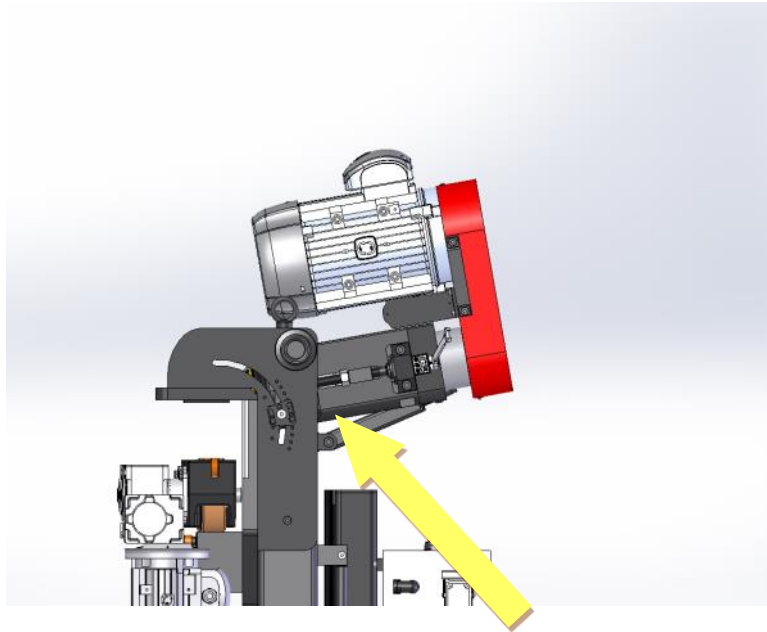
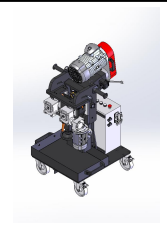

Tighten the 2 set screws on the sides adding the smaller fixing screws required to secure the side tiles to provide an additional security lock to the acquired position.

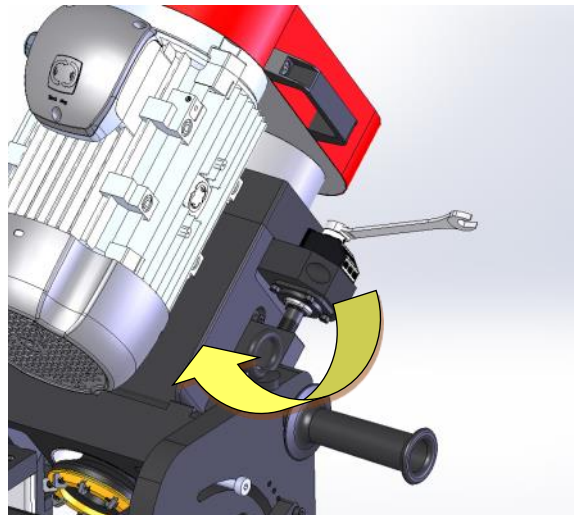

To increase the pass depth, thus the length of bevel, in first place you will need to loosen the locking nut of the DEPTH ADJUSTMENT ASSEMBLY.

**G.B.C. Industrial Tools S.p.A.**

Via Sandro Pertini 41/43 – 25046 Cazzago San Martino (Bs) – Italia – Tel. + 39 030 7451154 – Fax. + 39 030 73 56 629

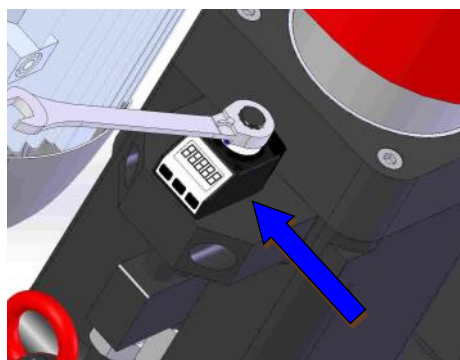
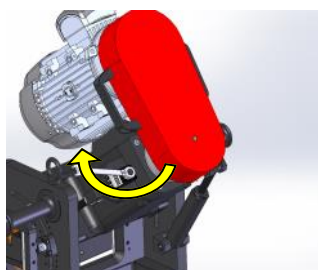
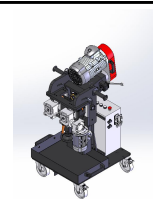

Now you can turn the hexagonal head of the feeding screw with the ratchet wrench supplied with the unit checking the actual depth on the LCD display just beneath it.

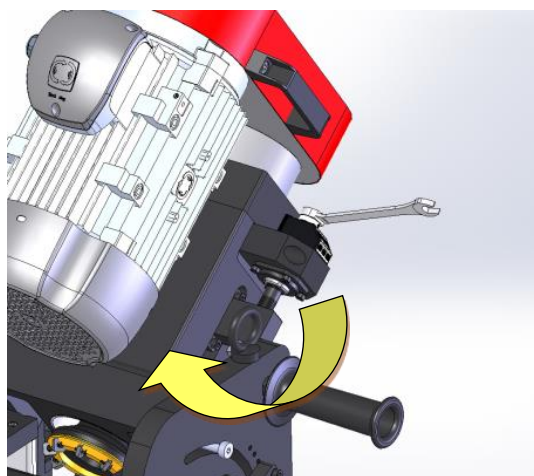

Once the desired depth is reached fasten the locking nut.

**G.B.C. Industrial Tools S.p.A.**

Via Sandro Pertini 41/43 – 25046 Cazzago San Martino (Bs) – Italia – Tel. + 39 030 7451154 – Fax. + 39 030 73 56 629

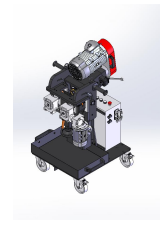

10° Angle		
Pass	Pass Depth	L
1	5.30	30.99
2	2.49	45.58
3	1.99	57.21
4	1.69	67.12
5	1.60	71.08
6	1.60	70.68
7	1.60	72.11

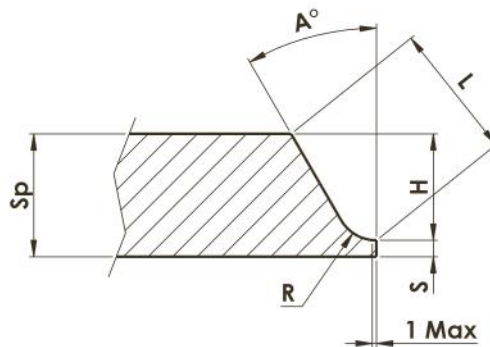

- Max Speed during the plate entering phase 0.2m/min
- Max Speed during the plate exiting phase 0.2m/min
- The beveling speed with a fully engaged plate is variable depending by the bevel angle, depth of the pass and by the material of the plate.

To have information about specific settings such as the face mill RPM, the machine travel speed on specific materials Per velocità di rotazione, velocità di avanzamento, tipologie di materiali e altri angoli, contattare

**G.B.C. Industrial Tools S.p.A.**

Via Sandro Pertini 41/43 – 25046 Cazzago San Martino (Bs) – Italia – Tel. + 39 030 7451154 – Fax. + 39 030 73 56 629

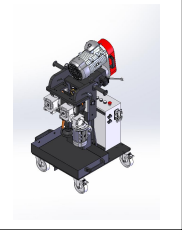

## CONTROLS

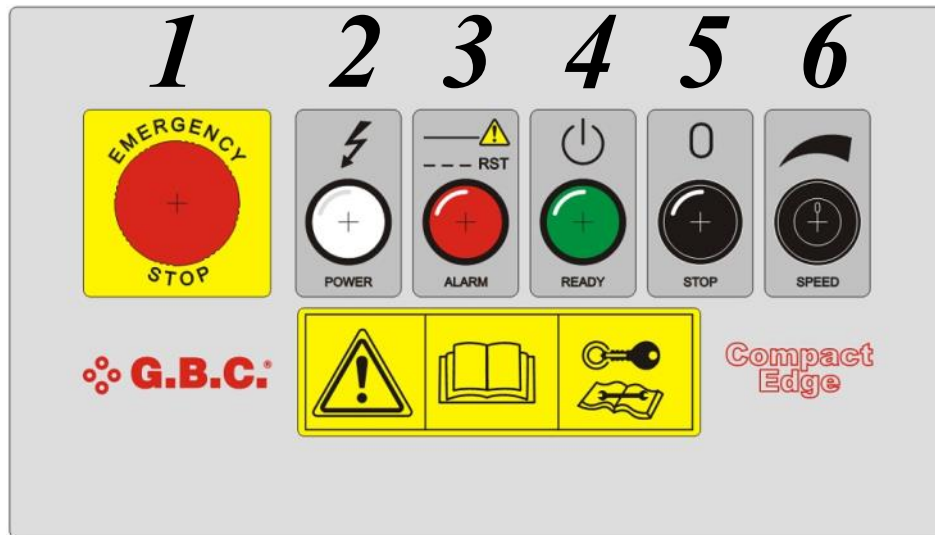

- 1 - Emergency Stop
- 2 - Power Presence
- 3 - Wrong Phase/ Inverter Alarm
- 4 - START / STOP Button With Plate Detection Light
- 5 - Face Mill and Feeding Stop
- 6 - Feeding Speed Regulator

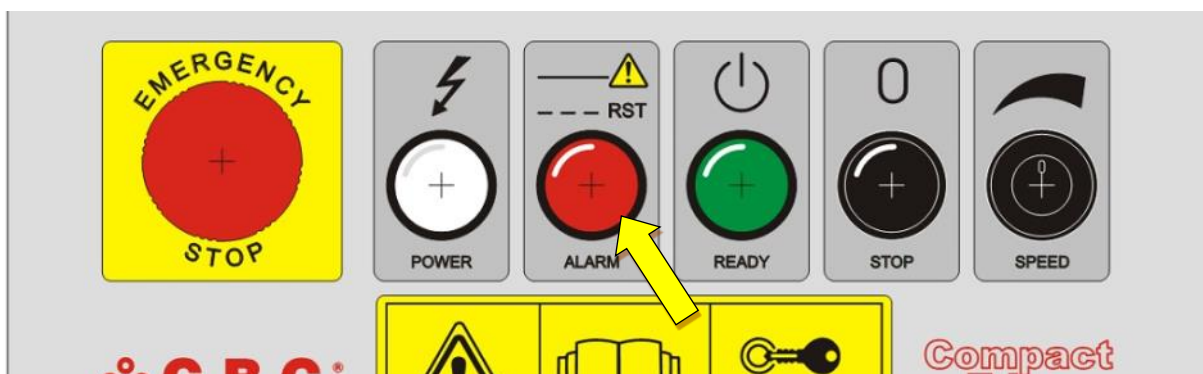

*If the red light is blinking the machine will not start because you need to change the phase in the power chord.*

*If the red light is still the machine is in protection mode. Reset the unit by turning off and on the main power switch .*

**G.B.C. Industrial Tools S.p.A.**

Via Sandro Pertini 41/43 – 25046 Cazzago San Martino (Bs) – Italia – Tel. + 39 030 7451154 – Fax. + 39 030 73 56 629

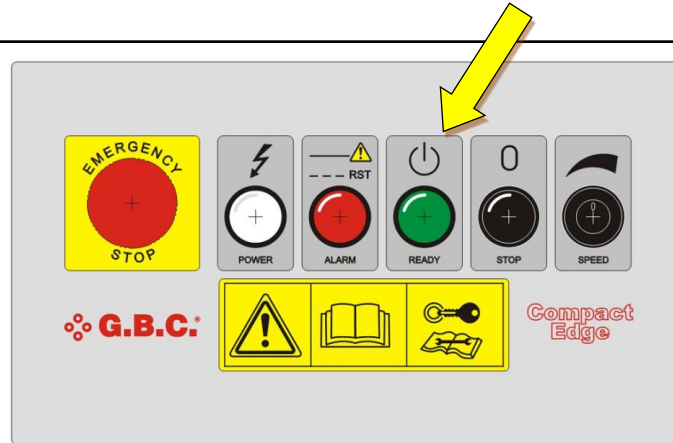
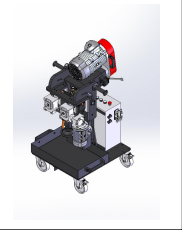

Once the machine is connected to the power source and it is positioned onto the plate as previously explained the green light will turn on .

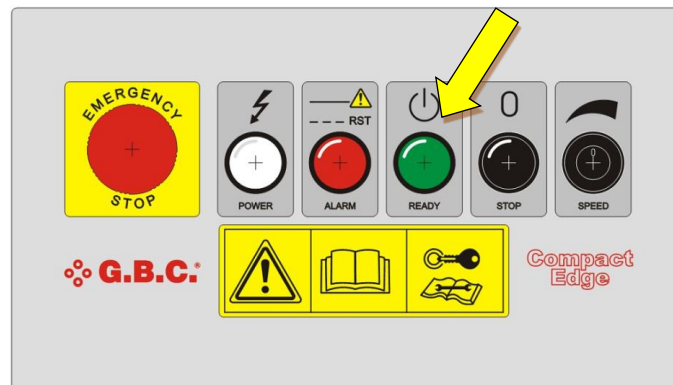

Start the machine by pushing the green button as shown in the above picture.  
The machine will then start working.

**G.B.C. Industrial Tools S.p.A.**

Via Sandro Pertini 41/43 – 25046 Cazzago San Martino (Bs) – Italia – Tel. + 39 030 7451154 – Fax. + 39 030 73 56 629

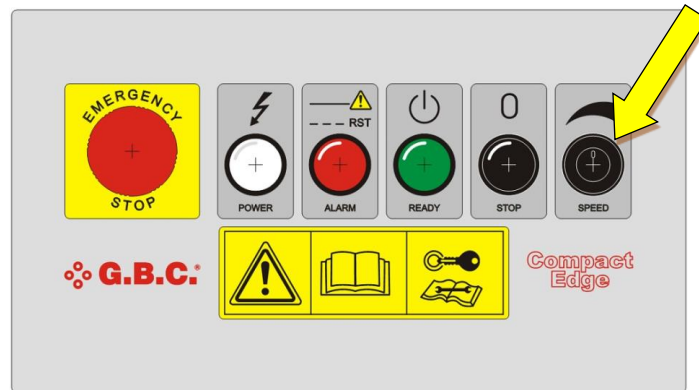
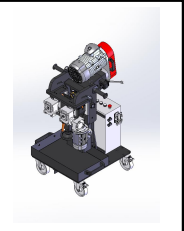

Adjust the Feeding Speed in relation to the material and the pass depth acting of the potentiometer pointed by the arrow.

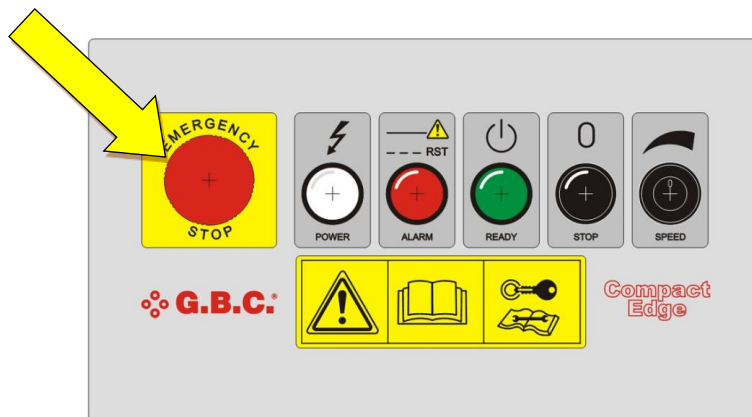

In case of emergency push the **EMERGENCY STOP BUTTON** for an immediate stop of the machine.

**G.B.C. Industrial Tools S.p.A.**

Via Sandro Pertini 41/43 – 25046 Cazzago San Martino (Bs) – Italia – Tel. + 39 030 7451154 – Fax. + 39 030 73 56 629

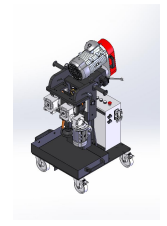

## **INSERTS REPLACEMENT**

Before proceeding with this operation make sure the unit is disconnected from the power source, the access area to the face mill is clean and that the face mill is easily accessible.

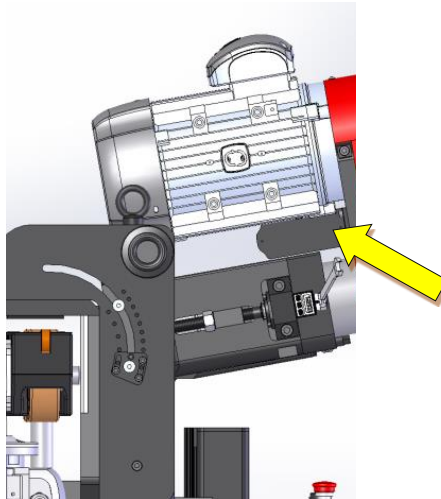

Set the head of the machine to a 45° angle.

**G.B.C. Industrial Tools S.p.A.**

Via Sandro Pertini 41/43 – 25046 Cazzago San Martino (Bs) – Italia – Tel. + 39 030 7451154 – Fax. + 39 030 73 56 629

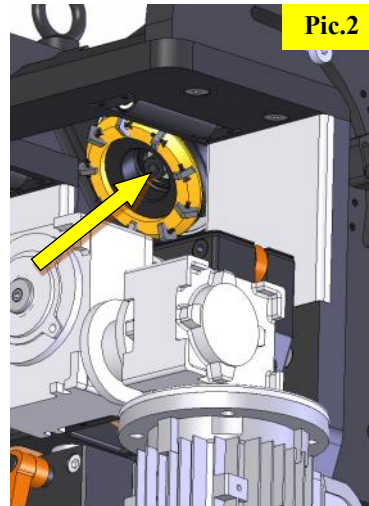
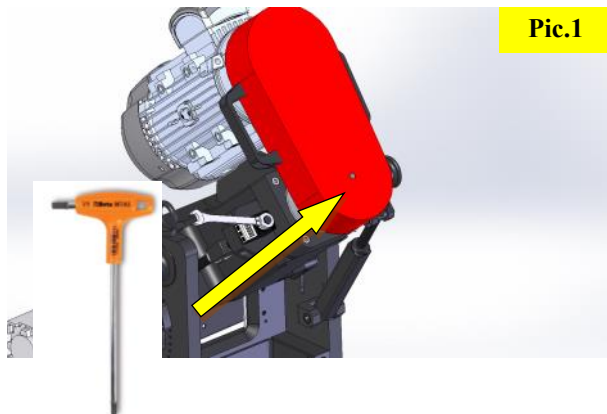
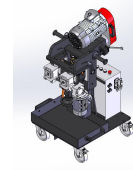

This operation can be easily carried out by one single operator. Use the long handle hex key (Pic.1) to reach the socket head cap of the shaft through the hole located on the red protection and at the same time engage the socket head cap of the Face Mill fixing screw (Pic.2) with the standard Allen Key supplied and hold it steady while with the other hand you turn the long handle hex key.

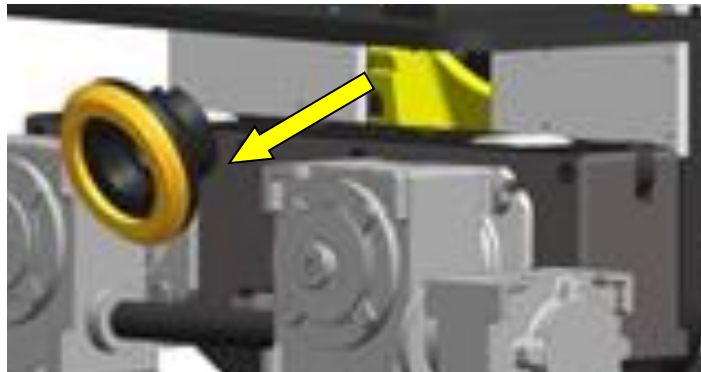

Remove the face mill

**G.B.C. Industrial Tools S.p.A.**

Via Sandro Pertini 41/43 – 25046 Cazzago San Martino (Bs) – Italia – Tel. + 39 030 7451154 – Fax. + 39 030 73 56 629

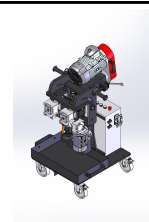

Rotate or replace the carbides using the torx key supplied with the machine tool kit.

Put the face mill back in its seat and fix it by following the dismantling instruction in reverse.

**G.B.C. Industrial Tools S.p.A.**

Via Sandro Pertini 41/43 – 25046 Cazzago San Martino (Bs) – Italia – Tel. + 39 030 7451154 – Fax. + 39 030 73 56 629

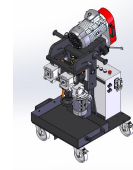

## **WARNINGS AND TROUBLESHOOTING**

Make sure that the unit gets cleaned with compressed air after every preparation, paying particular attention to the face mill hub which is where the shavings tend to bulk up.

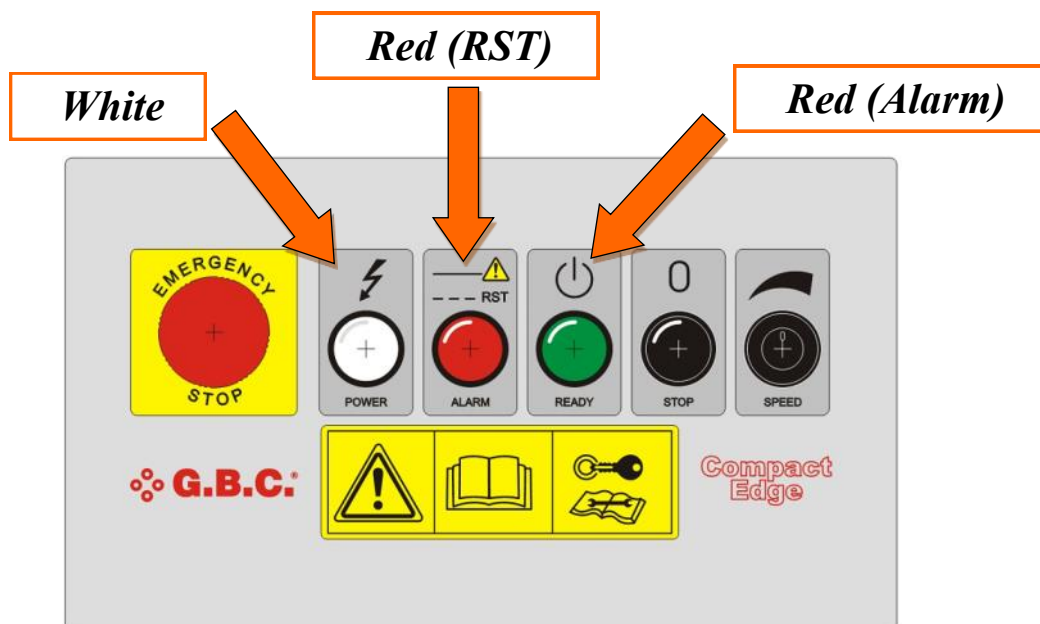

### **THE MACHINE DOES NOT WORK:**

- Verify that the **white** light is on.
- If the **red light (RST)** is blinking you need to switch the phases in the power chord.
- If the **red light (Alarm)** is turned on check the motor protection circuit breaker and/or error codes on the inverter display.
- If the machine should stop due to a mechanical problem the **red light** will turn on. Turn off the main switch and check for possible causes that led to the situation (feeding speed too high or pass too deep). Turn on the unit with the **main switch** and repeat the starting sequence.

**G.B.C. Industrial Tools S.p.A.**

Via Sandro Pertini 41/43 – 25046 Cazzago San Martino (Bs) – Italia – Tel. + 39 030 7451154 – Fax. + 39 030 73 56 629

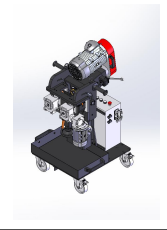

## **INSTALLATION AND USE OF THE FACE MILL SPEED REGULATOR**

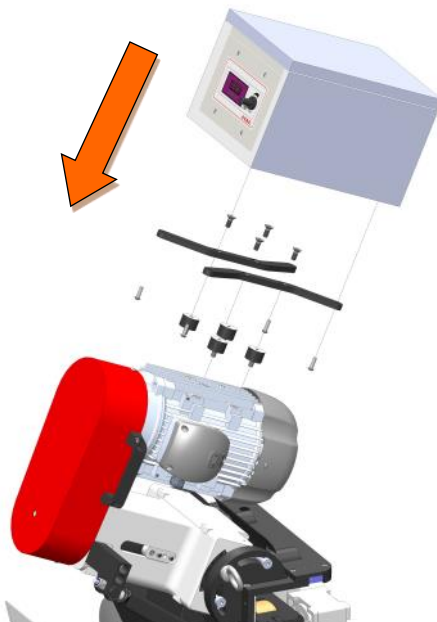

Install the Face Mill Speed Regulator on top of the motor as shown in the picture above.

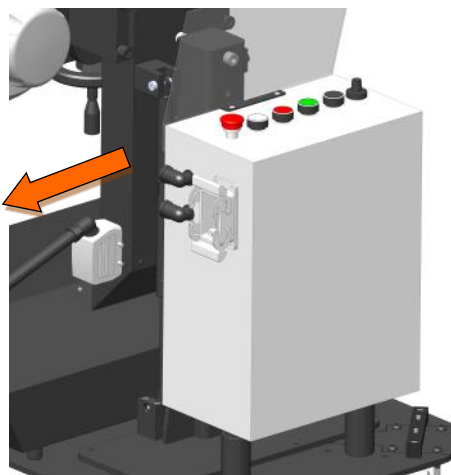

Disconnect the connector from the control panel as shown in the above picture.

**G.B.C. Industrial Tools S.p.A.**

Via Sandro Pertini 41/43 – 25046 Cazzago San Martino (Bs) – Italia – Tel. + 39 030 7451154 – Fax. + 39 030 73 56 629

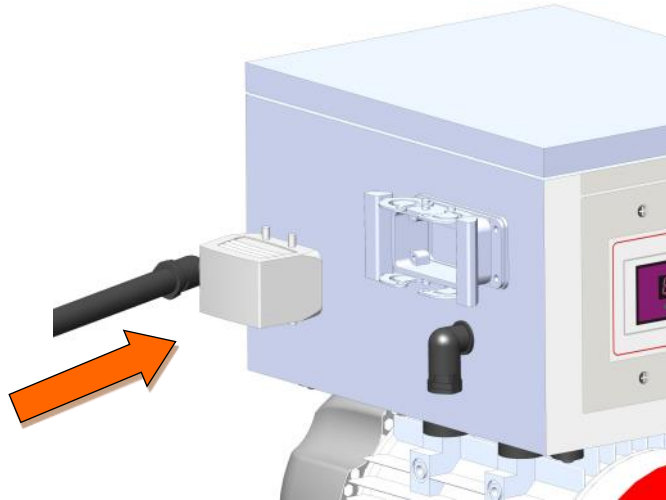
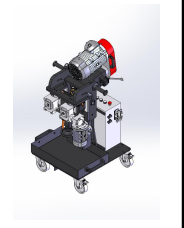

Now plug the same connector to the Speed Regulator

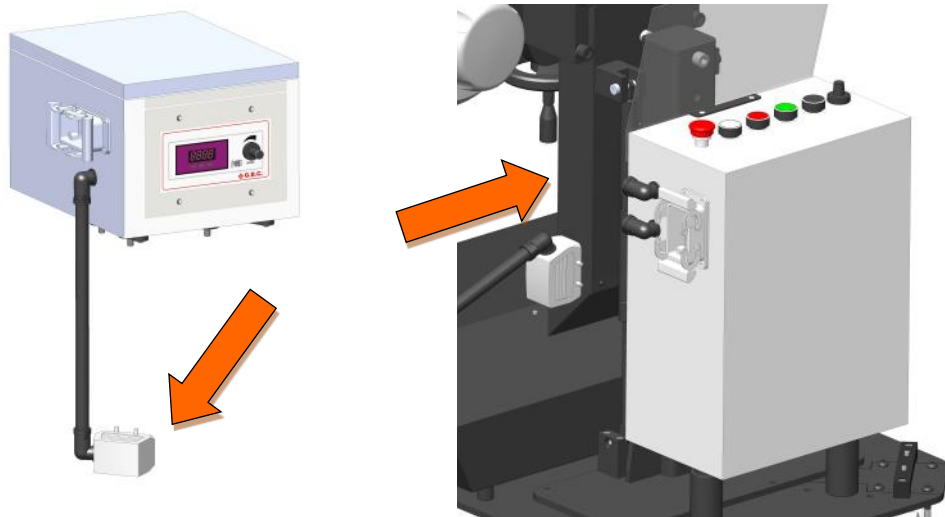

Plug the other end of the connector to the socket located on the left side of the power box as shown above.

**G.B.C. Industrial Tools S.p.A.**

Via Sandro Pertini 41/43 – 25046 Cazzago San Martino (Bs) – Italia – Tel. + 39 030 7451154 – Fax. + 39 030 73 56 629

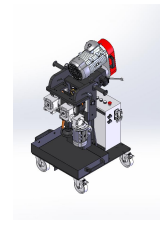

The speed of the Face Mill can now be adjusted by simply turning the knob counter-clockwise to reduce it or clockwise to increase it.



Refer to the previous paragraphs for the use of the machine.

**G.B.C. Industrial Tools S.p.A.**

Via Sandro Pertini 41/43 – 25046 Cazzago San Martino (Bs) – Italia – Tel. + 39 030 7451154 – Fax. + 39 030 73 56 629

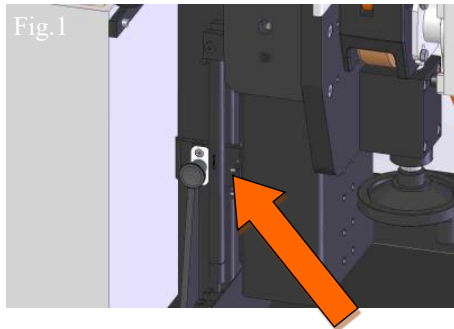
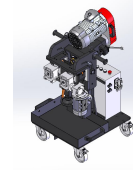

The wheels are equipped with brakes, in order to prevent the machine to move when working small plates.

The trolley has two locking positions:

- The lower position, used for the machine transportation in its wooden case(fig.1);
- - The higher position used during the normal working routine which allows the machine to “float” and automatically adjust its height during the beveling operations (fig.2).

In case the machine is moved by cranes or any other lifting device ensure the trolley is locked in the lower position with the two screws supplied with the machine. Lifting the machine without this precaution may damage the pistons and the linear guide of the trolley and causing the warranty to be void.

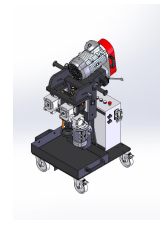

Ensure that the floor over which the machine will be operated is not inclined and that there are no holes or obstacles that may prevent the correct feeding of the machine.



The trolley suspension system is designed in order to allow the machine to follow eventual imperfections of irregular plates as well as of irregular floor surfaces.



# EDGE 80

Original Instructions —rev.2013—in compliance with § 1.7.4 of the Machine Directive 2006/42/CE

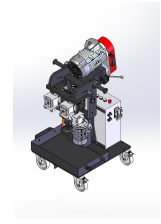

## **ORDINARY MAINTENANCE**

We suggest to perform a service c/o G.B.C. Industrial Tools S.p.A. premises every 400 hours working cycles.

## **PERIODICAL CHECKS**

- Always check the machine general conditions
  
- Always use well sharpened inserts

G.B.C. Industrial Tools is at your disposal for any information you may require about the above mentioned procedures and for any general clarification you may need.

**G.B.C. Industrial Tools S.p.A.**

Via Sandro Pertini 41/43 – 25046 Cazzago San Martino (Bs) – Italia – Tel. + 39 030 7451154 – Fax. + 39 030 73 56 629