

Model CH 8020

[View product here](#)

Tube size I.D 1.358 - " - 4000 " (34.5 - 101.6 mm)

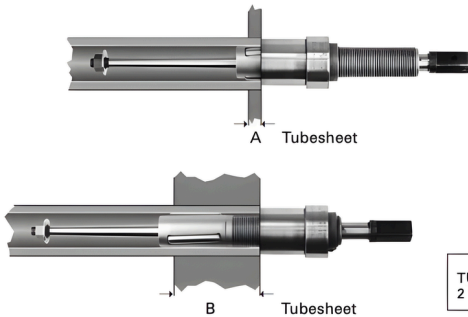

	TUBE SHEET THICKNESS	
	A MINIMUM	B MAXIMUM
TUBE EXPANDER WITH 2 1/4" ROLL LENGTH	1/4" (6.35 mm)	3 3/4" (95.25 mm)

TUBE O.D. AND G.A.	MIN. I.D. TUBE TOOL ENTERS		MAX. TOOL EXPANSION		SIZE SQUARE ON MANDREL	EXPANDER WITH 2 1/4" (57.1 mm) ROLLS		MANDREL NO.
	Inch	mm	Inch	mm		EXPANDER NO.	ROLL SET NO.	
1 3/4"- 8	1.358	34.50	1.552	39.42	3/4"	CH-8012-1 3/4-8	TR-33-A	MT-90
1 3/4"- 9-10	1.420	36.10	1.617	41.08		CH-8012-1 3/4-10	TR-37-A	MT-90
1 3/4"- 11	1.452	36.90	1.637	41.58		CH-8012-1 3/4-11	TR-42	MT-90
1 3/4"- 12	1.480	37.60	1.659	42.14		CH-8012-1 3/4-12	TR-44	MT-90
1 3/4"- 13	1.507	38.30	1.687	42.84		CH-8012-1 3/4-13	TR-46	MT-90
1 3/4"- 14	1.532	38.90	1.711	43.46		CH-8012-1 3/4-14	TR-48	MT-90
2"- 6-7	1.563	39.70	1.791	45.51		3/4"	CH-8012-2-6-7	TR-48
2"- 8-10	1.625	41.30	1.859	47.23	CH-8012-2-8-10		TR-50	MT-91
2"- 11	1.662	42.00	1.888	47.95	CH-8012-2-11		TR-52	MT-91
2"- 12	1.685	42.80	1.910	48.51	CH-8012-2-12		TR-54	MT-91
2"- 13-16	1.724	43.80	1.949	49.51	CH-8012-2-13-16		TR-56	MT-91
2 1/4"- 5	1.788	45.40	2.019	51.28	3/4"	CH-8012-2 1/4- 5	TR-50	MT-92
2 1/4"- 6-7	1.839	46.70	2.069	52.56		CH-8012-2 1/4- 6- 7	TR-54	MT-92
2 1/4"- 8-10	1.882	47.80	2.109	53.56		CH-8012-2 1/4- 8-10	TR-56	MT-92
2 1/4"- 11	1.921	48.50	2.137	54.28		CH-8012-2 1/4-11	TR-58	MT-92
2 1/4"- 12	1.933	49.10	2.159	54.84		CH-8012-2 1/4-12	TR-60	MT-92
2 1/4"- 13-16	1.936	49.80	2.187	55.56		CH-8012-2 1/4-13-16	TR-62	MT-92

Note: Expander CH 8012 is also available as four or five roll expander.

Model CH 8020

[View product here](#)

Tube size I.D 1.358 - " - 4000 " (34.5 - 101.6 mm)

TUBE O.D. AND G.A.	MIN. I.D. TUBE TOOL ENTERS		MAX. TOOL EXPANSION		SIZE SQUARE ON MAN- DREL	EXPANDER WITH 2 1/4" (57.1 mm) ROLLS		MANDREL NO.
	Inch	mm	Inch	mm		EXPANDER NO.	ROLL SET NO.	
2 1/2"-5-7	2.043	51.90	2.348	59.64	1"	CH-8012-2 1/2- 5- 7	TR-62	MT-96
2 1/2"-8-12	2.134	54.20	2.409	61.20	3/4"	CH-8012-2 1/2- 8-12	TR-64	MT-93
2 1/2"-13-16	2.232	56.70	2.437	61.90		CH-8012-2 1/2-13-16	TR-64	MT-94
2 3/4"-5-7	2.291	58.20	2.598	65.98	1"	CH-8012-2 3/4- 5- 7	TR-64	MT-96
2 3/4"-8-14	2.366	60.10	2.673	67.90		CH-8012-2 3/4- 8-14	TR-66	MT-96
3"-3-4	2.449	62.20	2.752	69.90	1"	CH-8012-3-3-4	TR-64	MT-97-SP
3"-5	2.478	62.90	2.791	70.90		CH-8012-3-5	TR-64	MT-98
3"-6-7	2.547	64.70	2.867	72.82		CH-8012-3-6-7	TR-66	MT-98
3"-8-14	2.618	66.50	2.924	74.26		CH-8012-3-8-14	TR-67	MT-96
3 1/4"-5-9	2.744	69.70	3.045	77.35	1"	CH-8012-3 1/4- 5- 9	TR-67	MT-97
3 1/4"-7-14	2.871	72.90	3.174	80.63		CH-8012-3 1/4- 7-14	TR-68	MT-97
3 1/2"-7-13	3.043	77.30	3.361	85.38	1"	CH-8012-3 1/2- 7-13	TR-69	MT-98
3 1/2"-8-14	3.122	79.30	3.440	87.38		CH-8012-3 1/2- 8-14	TR-69	MT-99
3 1/2"-11-18	3.224	81.90	3.543	89.98		CH-8012-3 1/2-11-18	TR-70	MT-99
4"-6-11	3.575	90.80	3.898	99.00	1"	CH-8012-4-6-11	TR-71	MT-99
4"-10-16	3.701	94.00	4.014	100.96		CH-8012-4-10-16	TR-72	MT-99
4"-12-18	3.732	94.80	4.050	102.86		CH-8012-4-12-18	TR-71	MT-100
4 1/4"-8-12	3.851	97.80	4.179	105.76	1"	CH-8012-4 1/4- 8-12	TR-72	MT-100
4 1/2"-2-3	3.851	97.80	4.179	105.76	1"	CH-8012-4 1/2- 2- 3	TR-72	MT-100

Note: Expander CH 8012 is also available as four or five roll expander.

